

FORD 302 ULTRA SERPENTINE STREET ROD KIT



Ultra Kit

March Performance has designed a spectacular kit around the 1994-1995 Mustang short water pump for improved engine to radiator clearance. This kit is completely machined from solid billet 6061-T6 aluminum! March Performance supplies the stainless steel tensioning rods, rod ends and all the necessary mounting hardware. This beautiful new machine finish is covered with a maintenance-free "No Polishing" clear powdercoat. We even go as far as hard coating the high wear areas on our high water flow ratio pulleys.

Application:

Early street rods or full size truck with 14" hood clearance from center of water pump shaft. 94 - 95 Mustang water pump and timing cover, No provision for dipstick with mechanical fuel pump must use oil pan type dipstick.

Kit Includes:

- Alternator and A/C brackets with Perfect Positioning™ bushing
- High water flow ratio pulley kit (crank, water pump with nose cover, alternator pulley, alternator fan and cover
- OEM Style tensioner, mounting bracket, covers and hardware
- A/C cover
- Power steering kit includes bracket and pulley

Optional Matching Billet Accessories:

- #450 billet remote power steering reservoir.



With OEM Style Tensioner
Tensioner delete minus
\$160.00 CALL

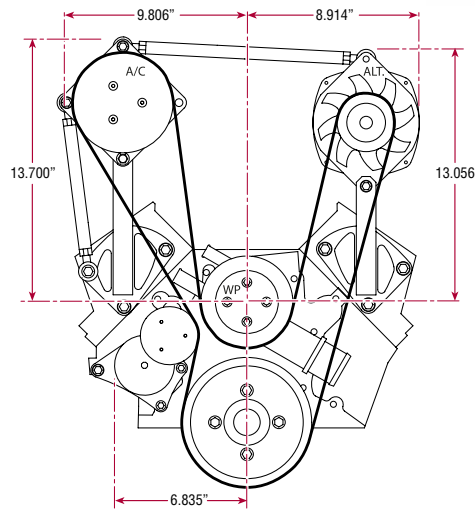

Ford 302 Serpentine Street Rod Kits

Kit # Drives	Alternator	A/C	Water Pump	Remote Reservoir Power Steering	Belt Size
30022	X	X	X		69"
30023	X	X	X	X	82.5"

Ford 351 Serpentine Street Rod Kits

30032	X	X	X		73.5"
30033	X	X	X	X	87"

Type of Accessories	Early Ford 6-12 o'clock mounting alternator	Sanden 505 or 508 serpentine A/C	1994-95 Mustang short water pump and timing cover, Ford Racing #M-8501-A50 or March #P500	GM 1987 6 cyl. Sunbird small remote reservoir pump	
---------------------	---	----------------------------------	---	--	--